

Residence R4 Classic

C. BECHSTEIN



Welcome to the exquisite German grand and upright piano manufactory.

”

Piano music should
only be written
for the Bechstein.

Claude Debussy

**Ever since 1853,
C. Bechstein has been
handcrafting the finest
masterpieces of
German piano tradition,
the gold standard for the
most sophisticated ears
and discerning fingers.**

The singing, lively sound of the Residence line inspires from the very first note. Professionals and beginners alike are drawn to the subtly controllable touch. The Classic, Contur, Elegance, Millenium and Style editions are true beauties.

Be it traditional profiles or elegant details, timeless shapes or modern design, each of these upright pianos is unique, enabling customers to select the perfect model to match their interiors.



Deep, colorful and dynamic sound, sparkling treble, shining, poetic

Traditional action frame with wooden rails, C. Bechstein hammer heads with walnut mouldings

Very robust pine back frame construction, soundboard support frame made from solid beech, diagonal support made from maple with mahogany inserts

Acoustic assembly in the traditional C. Bechstein design

Compatible with Bluetooth MIDI (C. Bechstein Connect)

Quality cabinets available in a wide range of styles, elegant forged concert pedals



UNIQUE. LIKE YOU. Create your piano exactly the way you like it! Choose from over 190 RAL colors — from deep, rich tones to soft pastels and bold, vibrant shades, in glossy or matte — unique just like you!

Residence R 4 Classic

Top quality – Handmade in Germany

The upright pianos of the Residence line in traditional C. Bechstein design impress with their singing, lively sound. The medium-sized C. Bechstein Residence R 4 is the epitome of balance. The playing feel alone impresses with its exceptional delicacy and effortlessness. The sound delights with a wonderful balance of overtones. In the Classic version, the R 4 also looks like a true classic.

Dimensions & weight	152.5 × 120 × 61.5 cm 218 kg 4' 0" × 3' 11" × 24.2" 481 lbs
Designs	Black, white; other finishes and veneers available on request
Soundboard	Selected, very fine-grained European mountain spruce
Action & Hammerheads	Original C. Bechstein components; Developed and produced by C. Bechstein
Pedals	Piano, Muffler, Forte (Damper)
Keys	Man-made white key tops with a pleasant grip & ebony sharps
Pin block	Multiple glued and compressed layers of beech (Delignit)

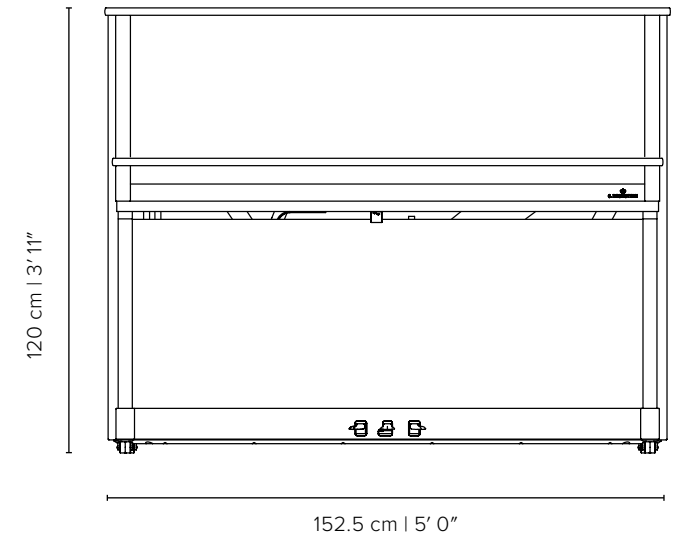
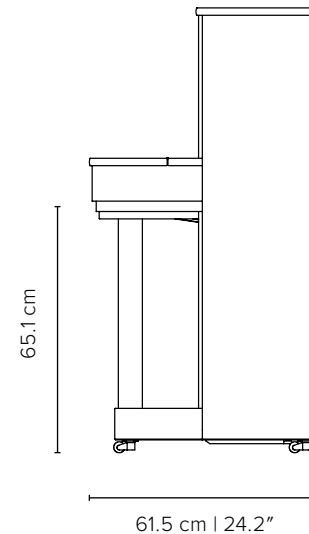

[→ Learn more about the model](#)

Residence R 4 Classic | Acoustic assembly

C. Bechstein RESILIENT SOUND SYSTEM

The unique and holistic engineering concept of C. Bechstein Residence upright pianos exclusively uses elements that support and enrich the sound. In combination with the C. Bechstein principle of sound-supporting tension, all components are carefully selected and balanced for dynamic range, volume, tone length and richly colorful sound, not to mention optimal tuning stability and outstanding longevity.

BACK FRAME

Six **highly robust**, quadruple-laminated braces made of layers of solid pine form the stable backbone of the upright piano. The sophisticated design with groove and mortise and tenon joint supports the vibrating soundboard and absorbs bending forces from the cast-iron frame. Soundboard support rails made from solid European beech; additional diagonal soundboard support in the bass and treble made from **maple with mahogany inserts** to enclose the vibrating soundboard. This quality construction guarantees climatic stability as well as impressive tonal volume and exceptional tuning stability. ①

PINBLOCK

High-quality **pinblock material** made from cross-laminated and compacted sheets of beech veneer for excellent, even tunability and tuning stability (**Delignit**).

TUNING PINS

Quality tuning pins made from nickle-plated steel, **6.9 mm × 64 mm**. Balanced torque, low torsion, excellent tunability and tuning stability, **with tuning pin bushings**.

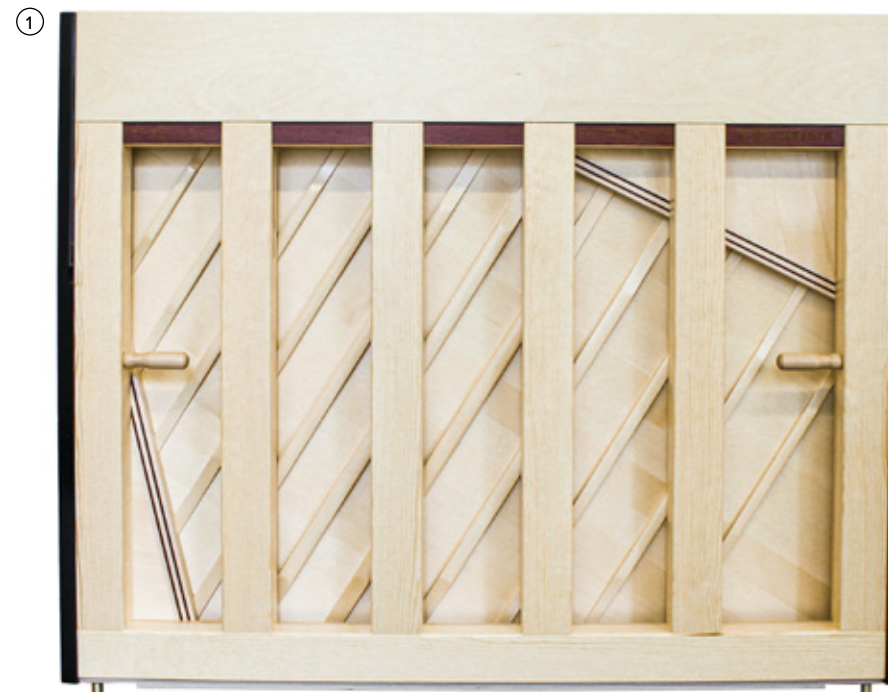

All sample images are representative of the line.



- ARTISANS - C. BECHSTEIN MANUFACTORY SEIFENHERRSDORF -

Residence R 4 Classic | Acoustic assembly

CAST-IRON FRAME

The cast-iron frame ② has the stability needed to withstand the enormous string-tension. Thanks to the careful sizing and traditional method of sand casting by hand, the cast-iron frame also enhances the sound.

STRINGS

Made from quality piano wire with high tensile strength and valuable copper wire from Germany, the strings have been calculated to maximize string length with balanced registers, harmonious overtone spectrum and excellent tuning stability. The strings are held in place by **agraffes** in keeping with C. Bechstein's traditional design. **Brass semi-circular aliquot bar in the treble.** ③

DUPLEX SYSTEM

Aliquot section with resonating strings to enrich the sound colors, without a duplex system.

SOUNDBOARD

The soundboard and ribs are made from **special-ly selected**, fine-grained European mountain spruce, which is stored for years and dried carefully. The bridges consist of solid European beech with European beech caps. The ribs are not tapered towards their end until they have been glued onto the soundboard. This promotes the elasticity of the soundboard. The diagonal soundboard support bars are designed to optimize the adaption of the soundboard to the string scale.

②



③



– ARTISANS – C. BECHSTEIN MANUFACTORY SEIFENHEHERSDORF –

Residence R 4 Classic | Action

C. BECHSTEIN DYNAMIC TOUCH DESIGN

The highly reliable C. Bechstein actions are developed in-house and allow perfect control and execution in any position of the key movement and offer quick repetition as well as a pleasant and even touch. Every key is balanced individually.

KEYBOARD

A quality keyboard made of solid spruce keys, man-made white key tops with a **pleasant grip** and ebony sharps. Precise key movements with high-quality, wear-resistant bushing felt.

C. BECHSTEIN ACTION ④

All components are designed, specified, selected, inspected and calibrated for precise and reliable function and durability. Strict selection and testing of all materials with regard to density, durability and gliding properties guarantee a reliable action at all times. **Traditional action frame with wooden rails.**

C. BECHSTEIN CONNECT

The piano piece is converted to MIDI and made available via Bluetooth. The original touch of the acoustic instrument is maintained.

C. BECHSTEIN HAMMER HEADS

Developed and produced in-house, C. Bechstein hammer heads ⑤ are a significant and consistent factor in the unique sound of the C. Bechstein Residence line – made with the highest-quality elastic felt and **walnut** mouldings.

The intricate, multi-stage process of voicing is performed to **C. Bechstein Residence quality standards.**

PEDALS

3 pedals: Piano (una corda), moderator and forte (damper)

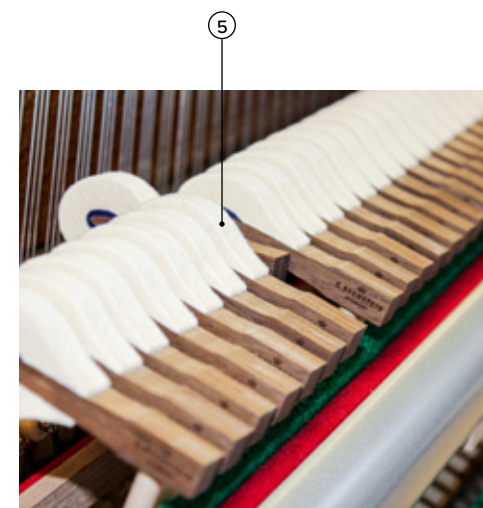



– ARTISANS – C. BECHSTEIN MANUFACTORY SEIFENHEHERSDORF –

Residence R 4 Classic | C. Bechstein Digital Systems

C. Bechstein Connect & Connect Pro

C. Bechstein Connect is a digital component for an acoustic instrument. While playing the piano, the system scans the keyboard and pedals of the instrument in high resolution and converts the data into MIDI, a universal musical instrument language. It connects to the popular apps via Bluetooth. The original touch of the acoustic instrument is maintained.

BLUETOOTH-MIDI

Connect smartphones, tablets or notebooks via Bluetooth to C. Bechstein Connect and popular apps for learning, playing or composing music.

SENSOR TECHNOLOGY ①

Optical sensors record the most subtle nuances in the movements of keys and pedals without making contact, providing flawless digital control over dynamics, articulation and agogic accents. Infrared sensors perform more than 200,000 measurements per second and calculate key velocity every 400 microseconds.

CONNECT PRO

The USB-C interface built into the C. Bechstein Connect Pro provides a wired connection with minimum latency for professional recordings in a studio.

Paired with the installation of the C. Bechstein hammer stop rail, which is configured for each individual instrument model, the instrument becomes a master keyboard.

POSSIBLE APPLICATIONS ②

MUSIC PRODUCTION

C. Bechstein Connect is compatible with popular DAW solutions such as Logic, Ableton and Cubase, making it easy to record piano pieces and produce music with plugins, loops and samples.

MUSICAL NOTATION

C. Bechstein Connect is compatible with notation software including Sibelius, Dorico and Finale, for notation in real time.

DIGITAL MUSIC LESSONS

C. Bechstein Connect and the all-in-one platform for digital music lessons doozoo (by C. Bechstein) are made for each other. In conjunction with C. Bechstein Connect, doozoo visualizes the notes played in a chord diagram or on the integrated virtual piano.

SOFTWARE INSTRUMENTS

Sample databases such as the Vienna Symphonic Library or virtual instruments like Pianoteq provide thousands of sounds for the piano.

The C. Bechstein Digital Grand Library sets new standards in the world of digital grand pianos.

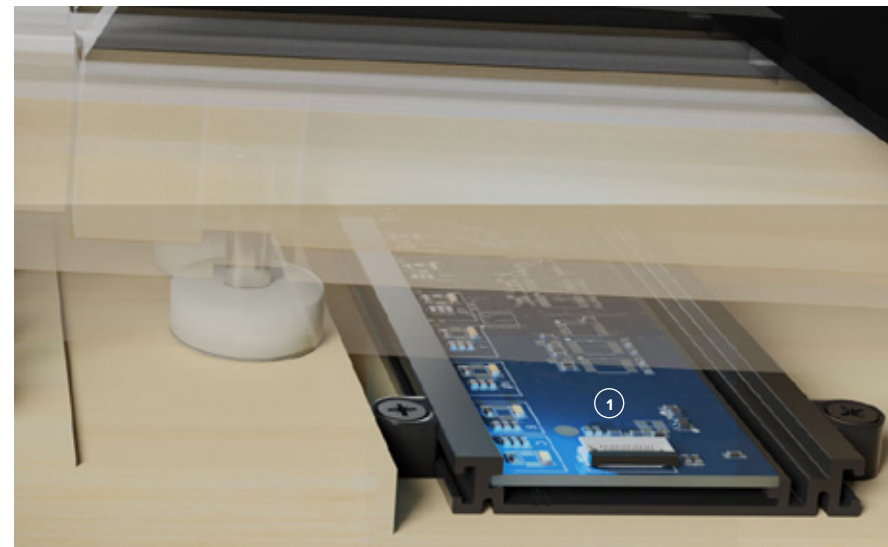

Residence R 4 Classic | Digital extensions (optional)

VARIO duet – Silent System

Das VARIO duet ③ adds a silent mode ④ and sound generation to C. Bechstein Connect. The sound module has two headphone outputs and high-fidelity Audio I/O.

OPERATION ⑤

Easy to operate with a single button. The built-in USB-C interface provides cutting-edge connectivity and recharges connected devices at high speeds of up to 45 W.

HAMMER STOP RAIL ⑥

The rail stops the hammers just before they touch the strings and mutes the acoustic piano. The original touch and the precise, controllable key strikes are maintained.

THE VARIO APP ⑦

The VARIO app for iOS / iPadOS and Android is the set-up and control centre for the VARIO digital system.

HEADPHONES ⑧

C. Bechstein headphones were developed especially for the VARIO silent systems. Their high fidelity and optimal wearing comfort are their hallmarks.

SOUND

The digital sound of the C. Bechstein Concert D-282 delivers a vast dynamic range and a remarkably sophisticated sound spectrum. Fully orchestral and clear across all registers for maximum artistic expressiveness.



Residence R 4 Classic | Technical data

DIMENSIONS, WEIGHTS, COLORS

Dimensions	152.5 × 120 × 61.5 cm 4' 0" × 3' 11" × 24.2"
Leg room	65.1 cm
Net weight	218 kg 481 lbs
Designs	Black, white; other finishes and veneers available on request

ACOUSTIC ASSEMBLY

Soundboard

Material	Selected, very fine-grained European mountain spruce
Tapering	8 mm

Ribs

Number	11
Material	Selected, very fine-grained European mountain spruce
Tapering	After gluing the ribs to the soundboard

Bridge

Bridge body	Solid beech
Bridge cap	Solid beech

Rim beams

Number	6
Material	Robust, triple-laminated and tapered braces made of solid pine
Dimensions	90 × 60 mm

Back frame / brace joints	Mortise and tenon joint in the lower beam, upper part glued with pinblock and rear plank, and solid blocks between the braces.
----------------------------------	--

Soundboard support	Solid Beech; diagonal corner resonators in bass and treble made of solid maple and Mahogany clearly define and support the soundboard area
---------------------------	--

Pinblock	Multiple glued and compressed layers of beech (Delignit)
-----------------	--

Tuning pins	Nickle-plated steel, 6.9 mm x 64 mm, with plate dowels
--------------------	--

Cast-iron frame	Sand-cast grey iron, drilled and milled with CNC technology
------------------------	---

Bass / Middle / Treble	30 / 28 / 30
-------------------------------	--------------

Agraffes

Material	Brass
Number of bass	30
Number of middle length	28
Treble	30

Number of overspun strings

Single strings	14
Bichords	16

Longest bass string	1,160 mm
----------------------------	----------

Longest tenor string	1,050 mm
-----------------------------	----------

Upper V-bar/Agraffes/Duplex	Agraffes
------------------------------------	----------

Rear string bearing (bridge)	Semi-circular brass bearing
-------------------------------------	-----------------------------

Residence R 4 Classic | Technical data

ACTION

White keytops	Man-made white keytops
Black keytops	Ebony
Key material	Selected spruce; with stable felt bushings treated for minimal friction and wear resistance
Total key length	377 mm
Key length front to capstan	352 mm
Key levers front/rear	208/144 mm
Capstan material	Brass

Action

Frame	Traditional action with wooden rails
Parts	Hornbeam
Down weight	Bass 52 g; Middle 51 g; Treble 50 g
Up weight	30 g – 34 g
3 pedals	Piano, Muffler, Forte (Damper)

HAMMERHEADS

Manufacturer	C. Bechstein Pianofortemanufaktur, Seifhennersdorf, Saxony, Germany
---------------------	---

Core wood type	Walnut
-----------------------	--------

FALLBOARD

Soft close	Optional
-------------------	----------

Lock	No lock, school equipment optional
-------------	------------------------------------

CASTERS

Type	Solid brass double wheel castors, school equipment optional
-------------	---

Diameter	30 mm
-----------------	-------

MANUFACTURER

Manufacturer	C. Bechstein Pianofortemanufaktur, Seifhennersdorf, Saxony, Germany
---------------------	---

Quality control	Quality control by C. Bechstein master piano makers and concert technicians
------------------------	---

Warranty	5 years manufacturers warranty by C. Bechstein, Germany
-----------------	---

**Established by
Carl Bechstein in Berlin
in 1853 and beloved
by the most significant
artists ever since, from
Franz Liszt to Elton John.**

C. Bechstein is one of the very few names to be synonymous with outstanding grand and upright pianos the world over. Established by Carl Bechstein in Berlin in 1853, the pianoforte workshop quickly grew into a company which, to this day, enjoys a stellar reputation in the eyes of musicians.

The quality of its pianos was valued by Franz Liszt, Richard Wagner and Hans von Bülow, as well as by Wilhelm Backhaus, Sergei Rachmaninoff and Leonard Bernstein.

The name “C. Bechstein” can even be found on the pages of pop and rock history. The greatest hits by Elton John, the Beatles, Queen and countless other artists were crafted on C. Bechstein pianos. This is due in no small part to the founder’s passion for development, to which the company remains beholden to this day.

Relentless research and development, supreme vertical integration down to the smallest details and continuous expert training mean our pianos represent the absolute pinnacle of piano construction — always in the spirit of C. Bechstein’s famed touch and sound.

**Fascinating
sound. Loved
and adored ever
since it was
developed by the
visionary master
piano maker
Carl Bechstein.**

PUBLISHING DETAILS

© 2026 C. Bechstein Sales & Service GmbH
Kantstraße 17 | 10623 Berlin
Phone: +49 (0)30 226 05 59 59
welcome@bechstein.com

www.bechstein.com

 bechstein.official

 bechstein.official

 C. Bechstein

Pictures: Pascal Bünning, C. Bechstein

C. Bechstein reserves the right to make technical changes to all models with regard to acoustic construction, cabinet, leg and lyre design and finishes.