

# Concert L-167

  
C. BECHSTEIN



# Welcome to the exquisite German grand and upright piano manufactory.

”

Piano music should  
only be written  
for the Bechstein.

Claude Debussy

**Ever since 1853,  
C. Bechstein has been  
handcrafting the finest  
masterpieces of  
German piano tradition,  
the gold standard for the  
most sophisticated ears  
and discerning fingers.**

Concert grand pianos represent the pinnacle of piano making. Our experienced craftspeople build these instruments to perfection using only the best materials. The result is an unbelievably pure, clear sound that remains highly sophisticated and articulate even into the extremes of the dynamic spectrum.

Tapered at the edges, the membranous, slightly arched soundboard is designed for optimal sound projection, stability and longevity, while the entire finely balanced acoustic assembly delivers incomparable sound transmission and responsiveness. This complex interplay allows for the most exquisite dynamic response, subtle nuances and incredibly rich partial tones.

Grand pianos from the Concert line are the peak of artistic expressiveness.

A three-dimensional, virtuosic sound with maximum dynamic range and depth, from the softest pianissimo to the powerful fortissimo

Powerful sound with rich color and overtones

Precise and dynamic touch, climatic stability

Optimal controllability in any position of the key movement

C. Bechstein action frame with metal sections filled with solid wood

C. Bechstein hammer heads with walnut mouldings

Tapered soundboard made from exceptionally fine-grained European spruce (grown at high elevations)

Inner rim made from layers of solid European beech and mahogany

Compatible with Bluetooth MIDI (C. Bechstein Connect)



— KOKI NAKANO — GUGGENHEIM MUSEO BILBAO —

# Concert L-167

## Top quality – Handmade in Germany

The professional grand piano in a compact format. An incredibly beautiful instrument with an amazingly voluminous and differentiated sound for its size. Experience the pleasantly controllable touch and nuancing possibilities typical of the Concert series on the L-167.

<b>Dimensions &amp; weight</b>	167 × 153 cm   317 kg 5'6" × 5'0"   699 lbs
<b>Designs</b>	Black, white; other finishes and veneers available on request
<b>Soundboard</b>	Selected, exceptionally fine-grained European mountain spruce (grown at highest elevations)
<b>Action &amp; hammerheads</b>	Original C. Bechstein components; Developed and produced by C. Bechstein
<b>Pedals</b>	Piano (Una Corda), Sostenuto, Forte (Dampers)
<b>Keys</b>	Man-made white key tops with a pleasant grip & ebony sharps
<b>Music stand</b>	Tiltable in 8 angles
<b>Lid prop</b>	3-piece, fully, half or slightly open lid

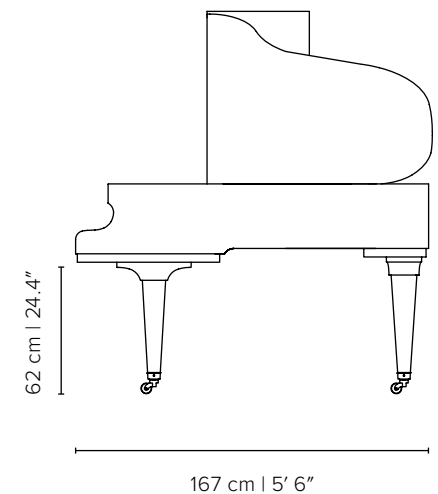
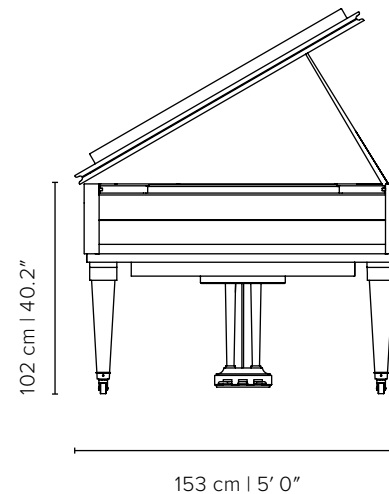

[→ Learn more about the model](#)

# Concert L-167 | Acoustic assembly

## C. BECHSTEIN RESILIENT SOUND SYSTEM

Carefully selected, cleverly balanced components as well as manufacturing techniques developed and carefully guarded by C. Bechstein guarantee sound-supporting tension, optimal tuning stability and exceptional longevity.

## INNER AND OUTER RIM

The inner rim constitutes the soundboard frame and consists of multiple **3 mm thick layers of European beech and mahogany** glued together to form a single piece. The outer rim is made from 3 mm thick layers of solid beech. Pretensioned by the method of gluing and balanced by the resting period, the inner rim helps prevent the loss of energy from the soundboard in the acoustic assembly.

## BACK FRAME

Made from **three continuous layers of pine** and tapered towards their end, the braces are glued to the inner rim using intricate yet durable **dovetail joints** ①. Three **eccentric European beech support blocks** connect the cast-iron frame to the back frame. The belly rail is made of solid beech and pine. The soundboard support rail on the belly rail, made from vertically laminated **layers of beech and mahogany**, is also glued to the inner rim, which is made of the same material, **by means of dovetail joint** ②.

## PINBLOCK

Block with three solid layers ③ of American hard maple, outer layers made from cross-laminated sheets of beech veneer. High proportion of solid wood for excellent and even tunability and tuning stability.

## TUNING PINS

Quality tuning pins ④ made from nickel-plated steel, **7.1 mm × 64 mm**. Balanced torque, low torsion, excellent tunability and tuning stability **with no tuning pin bushings**.

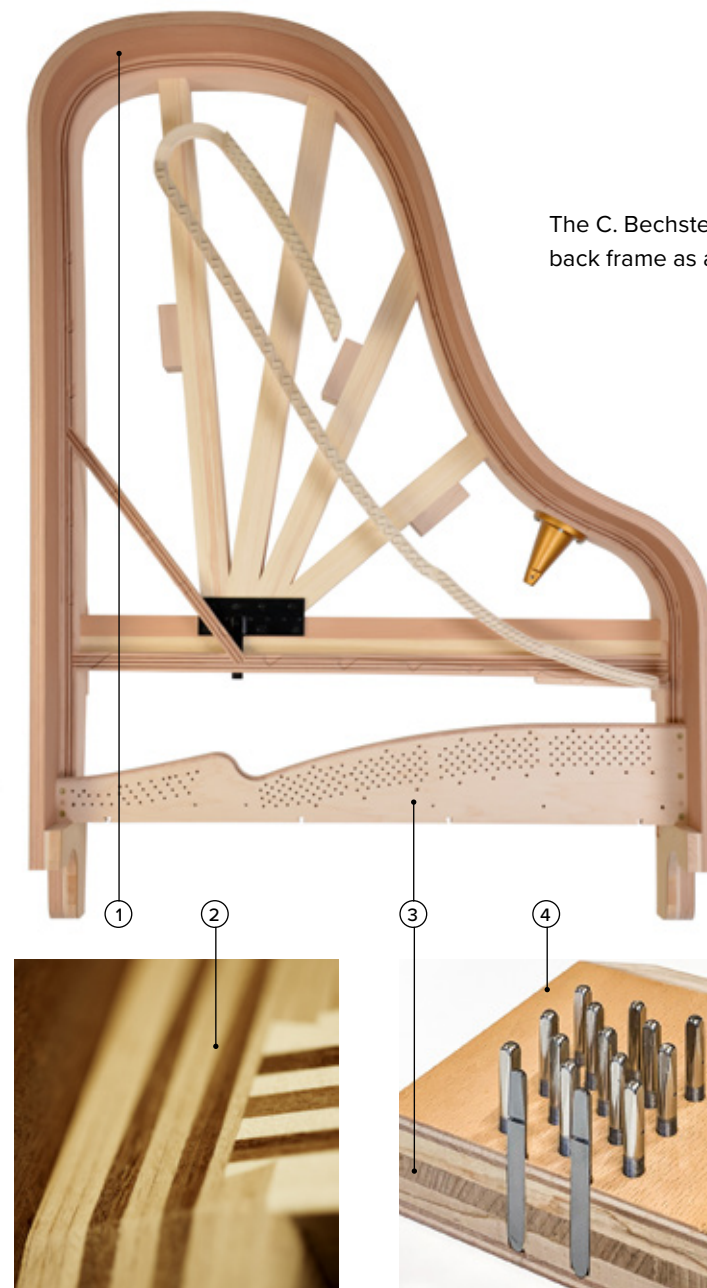

The C. Bechstein Concert B-212 back frame as an example



– ARTISANS – C. BECHSTEIN MANUFACTORY SEIFENHERSDORF –

# Concert L-167 | Acoustic assembly

## CAST-IRON FRAME

The cast-iron frame has the stability needed to withstand the enormous string-tensions. Thanks to the careful sizing and traditional method of sand casting by hand, the cast-iron frame also enhances the sound – supported by an adjustable cast-iron **resonator system** in the treble strings of B, C and D models. The special method of sand casting with furan resin produces a sound propagation speed of 4,000 metres per second.

## STRINGS

Made from quality piano wire with high tensile strength and valuable copper wire from Germany, the strings have been calculated to maximize string length with a balanced register, harmonious partials and excellent tuning stability. C. Bechstein agraffes in bass and the middle range, **with steel cores in the middle range**. Capo d'astro with duplex strings in the treble section, duplex scaling in the rear middle and treble section.

## DUPLEX SYSTEM ⑤

Resonating duplex strings enrich the color and vibrancy of the tone. The system comprises the front duplex strings at a defined angle to the speaking length for a clear, colorful sound, as well as the rear duplex strings that enrich the harmonic overtones of the strings, mainly tuned in fifths and octaves.

## SOUNDBOARD

The soundboard and ribs are made from specially selected, fine-grained, Concert-standard European mountain spruce, which is stored for years and dried carefully. The bridges consist of vertically laminated layers of **European maple with hornbeam caps**. The **long bridge and bass bridge** are connected to one another in the B, C and D models. The board is tapered from 9 mm in the centre **to 7.5 mm at the edge**. The ribs are not tapered towards their end until they have been glued onto the soundboard. The back frame and outer rim are fully glued and stored for months before the soundboard is glued on.

Top view of the C. Bechstein Concert B-212





– ARTISANS – C. BECHSTEIN MANUFACTORY SEIFENHERSDORF –

# Concert L-167 | Action

## C. BECHSTEIN DYNAMIC TOUCH DESIGN

Developed by C. Bechstein in-house, the highly reliable actions allow perfect control and execution in any position of the key movement and offer quick repetition as well as a pleasant and even touch. Every key is balanced individually.

## KEYBOARD

A quality keyboard made of solid spruce keys, man-made white key tops with a **pleasant grip** and ebony sharps. Precise key movements with high-quality, wear-resistant bushing felt. Adjustable glide bolts support the balance rail. Precise and perfectly adjustable keyboard guidance mechanism in the cheek block.

## C. BECHSTEIN ACTION ⑥

All components are designed, specified, selected, inspected and calibrated for precise and reliable function and durability. Strict selection and testing of all materials with regard to density, durability and gliding properties guarantee a reliable action at all times.

**The robust C. Bechstein action frame made of brass rails filled with solid wood promotes a precise, dynamic touch and climate stability.**

## C. BECHSTEIN CONNECT

High-resolution, contactless infrared sensors record the piano piece, convert it to MIDI and make it available via Bluetooth. The original touch of the acoustic instrument is maintained.

## C. BECHSTEIN HAMMERHEADS

Developed and produced in-house, C. Bechstein hammerheads ⑦ are a significant and consistent factor in the unique sound of the C. Bechstein Concert line – made with the highest-quality elastic felt and **walnut** mouldings. The intricate, multi-stage process of voicing is carried out by selected C. Bechstein **master piano craftspeople and concert technicians.**

## PEDALS

3 pedals: Piano (una corda), sostenuto and forte (damper)

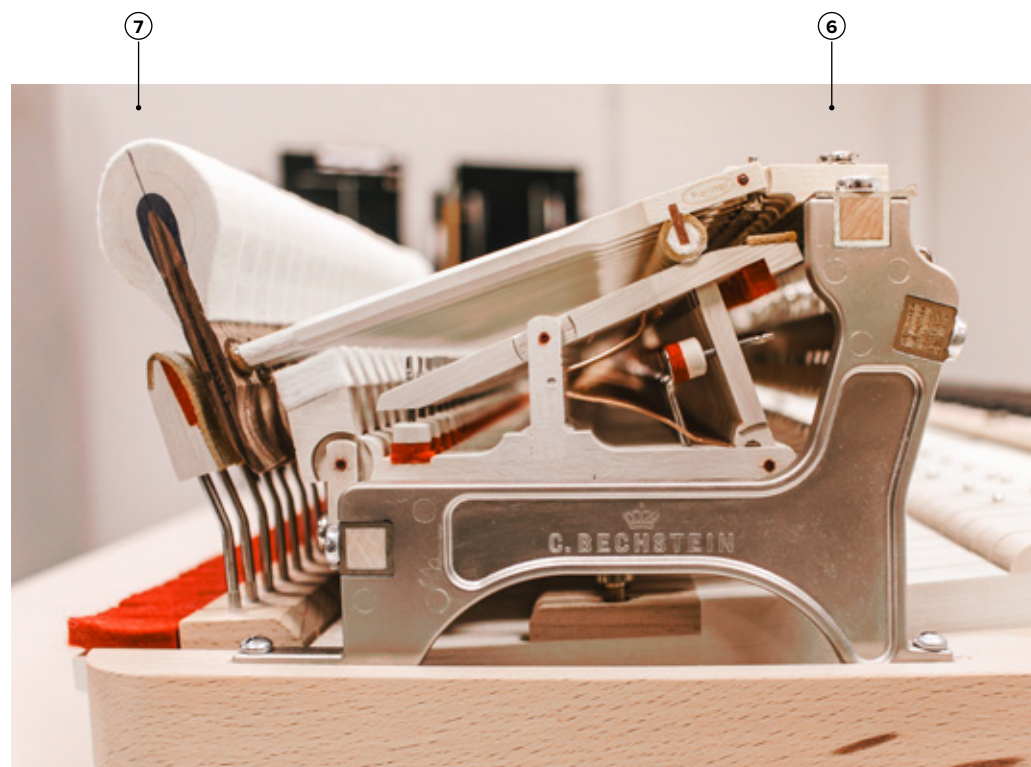
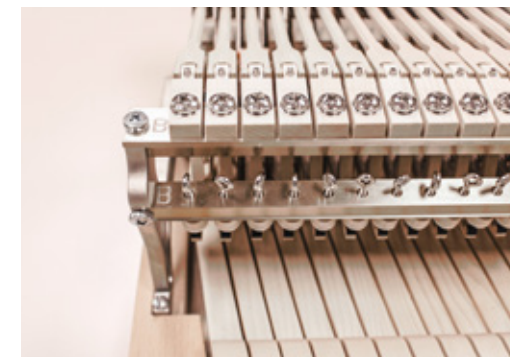



— ARTISANS — C. BECHSTEIN MANUFACTORY SEIFENHERRSDORF —

# Concert L-167 | C. Bechstein Digital Systems

## C. Bechstein Connect & Connect Pro

C. Bechstein Connect is a digital component for an acoustic instrument. While playing the piano, the system scans the keyboard and pedals of the instrument in high resolution and converts the data into MIDI, a universal musical instrument language. It connects to the popular apps via Bluetooth. The original touch of the acoustic instrument is maintained.

### BLUETOOTH-MIDI

Connect smartphones, tablets or notebooks via Bluetooth to C. Bechstein Connect and popular apps for learning, playing or composing music.

### SENSOR TECHNOLOGY ①

Optical sensors record the most subtle nuances in the movements of keys and pedals without making contact, providing flawless digital control over dynamics, articulation and agogic accents. Infrared sensors perform more than 200,000 measurements per second and calculate key velocity every 400 microseconds.

### CONNECT PRO

The USB-C interface built into the C. Bechstein Connect Pro provides a wired connection with minimum latency for professional recordings in a studio.

Paired with the installation of the C. Bechstein hammer stop rail, which is configured for each individual instrument model, the instrument becomes a master keyboard.

### POSSIBLE APPLICATIONS ②

#### MUSIC PRODUCTION

C. Bechstein Connect is compatible with popular DAW solutions such as Logic, Ableton and Cubase, making it easy to record piano pieces and produce music with plugins, loops and samples.

#### MUSICAL NOTATION

C. Bechstein Connect is compatible with notation software including Sibelius, Dorico and Finale, for notation in real time.

#### DIGITAL MUSIC LESSONS

C. Bechstein Connect and the all-in-one platform for digital music lessons doozoo (by C. Bechstein) are made for each other. In conjunction with C. Bechstein Connect, doozoo visualizes the notes played in a chord diagram or on the integrated virtual piano.

#### SOFTWARE INSTRUMENTS

Sample databases such as the Vienna Symphonic Library or virtual instruments like Pianoteq provide thousands of sounds for the piano.

The C. Bechstein Digital Grand Library sets new standards in the world of digital grand pianos.

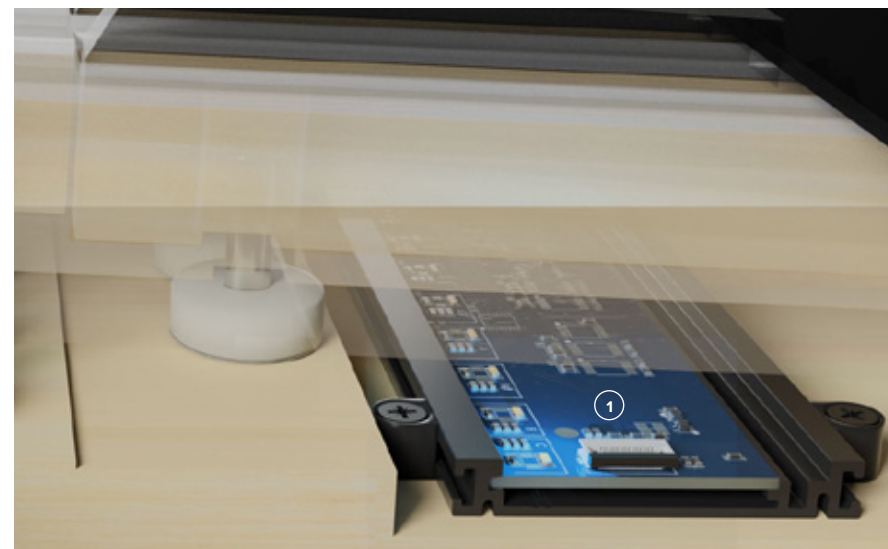

# Concert L-167 | Digital extensions (optional)

## VARIO duet – Silent System

Das VARIO duet ③ adds a silent mode ④ and sound generation to C. Bechstein Connect. The sound module has two headphone outputs and high-fidelity Audio I/O.

### OPERATION ⑤

Easy to operate with a single button. The built-in USB-C interface provides cutting-edge connectivity and recharges connected devices at high speeds of up to 45 W.

### HAMMER STOP RAIL ⑥

The rail stops the hammers just before they touch the strings and mutes the acoustic piano. The original touch and the precise, controllable key strikes are maintained.

### THE VARIO APP ⑦

The VARIO app for iOS / iPadOS and Android is the set-up and control centre for the VARIO digital system.

### HEADPHONES ⑧

C. Bechstein headphones were developed especially for the VARIO silent systems. Their high fidelity and optimal wearing comfort are their hallmarks.

### SOUND

The digital sound of the C. Bechstein Concert D-282 delivers a vast dynamic range and a remarkably sophisticated sound spectrum. Fully orchestral and clear across all registers for maximum artistic expressiveness.



# Concert L-167 | Technical data

## DIMENSIONS, WEIGHTS, COLORS

<b>Dimensions</b>	167 × 153 cm   5'6" × 5'0"
<b>Leg room</b>	62 cm   24.4"
<b>Net weight</b>	317 kg   699 lbs
<b>Colors</b>	Black, white; other finishes and veneers available on request

## ACOUSTIC ASSEMBLY

### Soundboard

<b>Material</b>	Selected, exceptionally fine-grained European mountain spruce (grown at highest elevations)
<b>Tapering</b>	Tapered; thickness at the center 9 mm, thickness at the outer edge 7.5 mm

### Ribs

<b>Number</b>	11
<b>Material</b>	Selected, exceptionally fine-grained European mountain spruce (grown at highest elevations)
<b>Tapering</b>	After gluing the ribs to the soundboard

### Bridge

<b>Bridge body</b>	Vertical layers of European maple
<b>Bridge cap</b>	Hornbeam

### Rim beams

<b>Number</b>	3
<b>Material</b>	Made from three continuous glued layers of pine and tapered towards their end
<b>Dimensions</b>	65 cm × 117 cm

**Belly rail** Made of solid beech and pine

<b>Rim</b>	Vertically glued solid layers of beech and pine
<b>Connection beams &amp; rim</b>	Dovetail joint, additional diagonal dowels
<b>Position of plate bolts</b>	Three eccentric European beech support blocks
<b>Piinblock</b>	C. Bechstein pin block with three cross-laminated, solid hard maple layers, outer layers made from cross-laminated sheets of beech veneer.
<b>Tuning pins</b>	Nickle-plated steel, 7.1 mm × 64 mm, without wooden plate bushings
<b>Cast-iron frame</b>	Traditional sand-casting in furan resin molds, drilled and milled with CNC technology. Sound propagation speed of min. 4,000 metres per second
<b>Bass / Middle / Treble 1 / Treble 2</b>	25 / 27 / 18 / 18
<b>Agraffes</b>	
<b>Material</b>	Brass
<b>Number of bass</b>	25
<b>Number of middle length</b>	27
<b>Treble</b>	Capo d'astro bar
<b>Number of overspun strings</b>	
<b>Single strings</b>	15
<b>Bichords</b>	12
<b>Longest bass string</b>	1,200 mm
<b>Longest tenor string</b>	1,006 mm
<b>Front duplex</b>	Both treble sections
<b>Rear duplex</b>	Treble and upper middle section
<b>Bell</b>	no

# Concert L-167 | Technical data

## ACTION

<b>White keytops</b>	Man-made white key tops with a pleasant grip
<b>Black keytops</b>	Ebony
<b>Key material</b>	Selected spruce; with stable felt bushings treated for minimal friction and wear resistance
<b>Total length Key 1</b>	497 mm
<b>Total length Key 88</b>	497 mm
<b>Key 1 levers: front / rear</b>	245/120 mm
<b>Key 88 levers: front / rear</b>	245/120 mm
<b>Key frame</b>	Made from spruce with front rail and balance rail made of solid oak. 5 adjustable brass glide bolts.
<b>Key bed</b>	Stable keyframe design with front and rear piece made from laminated solid pine, side bars made of solid beech. Middle pieces made from laminated solid pine, POM Inlays to reduce the friction of glide bolts.
<b>Keyboard guidance</b>	Precise and perfectly adjustable keyboard guidance mechanism in the cheek block.
<b>Action</b>	
<b>Frame</b>	C. Bechstein action; brass rails filled with solid wood.
<b>Parts</b>	Hornbeam
<b>Down weight</b>	Bass: 52 g   Middle: 50 g   Treble: 48 g (+/- 1g)
<b>Up weight</b>	Bass: 26 g   Middle: 28 g   Treble: 30 g (+/- 1g)
<b>3 pedals</b>	Piano (Una Corda), Sostenuto, Forte (Dampers)

## HAMMERHEADS

<b>Manufacturer</b>	C. Bechstein Pianofortemanufaktur, Seifhennersdorf, Saxony, Germany
<b>Core wood type</b>	Walnut

## MUSIC STAND

<b>Positions</b>	tiltable in 8 angles
------------------	----------------------

## LID

<b>Lid support / lid positions</b>	3-piece, fully, half or slightly open lid
------------------------------------	---

## FALLBOARD

<b>Soft close</b>	Softclose fallboard
<b>Lock</b>	Lock for fallboard and lid

## CASTERS

<b>Single / Double wheel, brake</b>	Solid brass single wheel castors with cup
<b>Diameter</b>	48 mm

## MANUFACTURER

<b>Manufacturer</b>	C. Bechstein Pianofortemanufaktur, Seifhennersdorf, Saxony, Germany
<b>Quality control</b>	Quality control by C. Bechstein master piano makers and concert technicians
<b>Warranty</b>	5 years manufacturers warranty by C. Bechstein, Germany

**Established by  
Carl Bechstein in Berlin  
in 1853 and beloved  
by the most significant  
artists ever since, from  
Franz Liszt to Elton John.**

C. Bechstein is one of the very few names to be synonymous with outstanding grand and upright pianos the world over. Established by Carl Bechstein in Berlin in 1853, the pianoforte workshop quickly grew into a company which, to this day, enjoys a stellar reputation in the eyes of musicians.

The quality of its pianos was valued by Franz Liszt, Richard Wagner and Hans von Bülow, as well as by Wilhelm Backhaus, Sergei Rachmaninoff and Leonard Bernstein.

The name “C. Bechstein” can even be found on the pages of pop and rock history. The greatest hits by Elton John, the Beatles, Queen and countless other artists were crafted on C. Bechstein pianos. This is due in no small part to the founder’s passion for development, to which the company remains beholden to this day.

Relentless research and development, supreme vertical integration down to the smallest details and continuous expert training mean our pianos represent the absolute pinnacle of piano construction — always in the spirit of C. Bechstein’s famed touch and sound.

**Fascinating  
sound. Loved  
and adored ever  
since it was  
developed by the  
visionary master  
piano maker  
Carl Bechstein.**

#### **PUBLISHING DETAILS**

© 2026 C. Bechstein Sales & Service GmbH  
Kantstraße 17 | 10623 Berlin  
Phone: +49 (0)30 226 05 59 59  
welcome@bechstein.com

[www.bechstein.com](http://www.bechstein.com)

 bechstein.official

 bechstein.official

 C. Bechstein

Pictures: Pascal Bünning, C. Bechstein

C. Bechstein reserves the right to make technical changes to all models with regard to acoustic construction, cabinet, leg and lyre design and finishes.